



Model 111A24

General purpose ICP® pressure probe, 1000 psi, 5 mV/psi, 0.218" dia.

Installation and Operating Manual

**For assistance with the operation of this product,
contact PCB Piezotronics, Inc.**

**Toll-free: 800-828-8840
24-hour SensorLine: 716-684-0001
Fax: 716-684-0987
E-mail: info@pcb.com
Web: www.pcb.com**





Warranty, Service, Repair, and Return Policies and Instructions
--

The information contained in this document supersedes all similar information that may be found elsewhere in this manual.

Total Customer Satisfaction – PCB Piezotronics guarantees Total Customer Satisfaction. If, at any time, for any reason, you are not completely satisfied with any PCB product, PCB will repair, replace, or exchange it at no charge. You may also choose to have your purchase price refunded in lieu of the repair, replacement, or exchange of the product.

Service – Due to the sophisticated nature of the sensors and associated instrumentation provided by PCB Piezotronics, user servicing or repair is not recommended and, if attempted, may void the factory warranty. Routine maintenance, such as the cleaning of electrical connectors, housings, and mounting surfaces with solutions and techniques that will not harm the physical material of construction, is acceptable. Caution should be observed to insure that liquids are not permitted to migrate into devices that are not hermetically sealed. Such devices should only be wiped with a dampened cloth and never submerged or have liquids poured upon them.

Repair – In the event that equipment becomes damaged or ceases to operate, arrangements should be made to return the equipment to PCB Piezotronics for repair. User servicing or repair is not recommended and, if attempted, may void the factory warranty.

Calibration – Routine calibration of sensors and associated instrumentation is recommended as this helps build confidence in measurement accuracy and acquired data. Equipment calibration cycles are typically established by the users own quality regimen. When in doubt about a calibration cycle, a good “rule of thumb” is to recalibrate on an annual basis. It is also good practice to recalibrate after exposure to any severe temperature extreme, shock, load, or other environmental influence, or prior to any critical test.

PCB Piezotronics maintains an ISO-9001 certified metrology laboratory and offers calibration services, which are accredited by A2LA to ISO/IEC 17025, with full traceability to SI through N.I.S.T. In addition to the normally supplied calibration, special testing is also available, such as: sensitivity at elevated or cryogenic temperatures, phase response, extended high or low frequency response, extended range, leak testing, hydrostatic pressure testing, and others. For information on standard recalibration services or special testing, contact your local PCB Piezotronics distributor, sales representative, or factory customer service representative.

Returning Equipment – *Following these procedures will insure that your returned materials are handled in the most expedient manner.* Before

returning any equipment to PCB Piezotronics, contact your local distributor, sales representative, or factory customer service representative to obtain a Return **Warranty, Service, Repair, and Return Policies and Instructions** Materials Authorization (RMA) Number. This RMA number should be clearly marked on the outside of all package(s) and on the packing list(s) accompanying the shipment. A detailed account of the nature of the problem(s) being experienced with the equipment should also be included inside the package(s) containing any returned materials.

A Purchase Order, included with the returned materials, will expedite the turn-around of serviced equipment. It is recommended to include authorization on the Purchase Order for PCB to proceed with any repairs, as long as they do not exceed 50% of the replacement cost of the returned item(s). PCB will provide a price quotation or replacement recommendation for any item whose repair costs would exceed 50% of replacement cost, or any item that is not economically feasible to repair. For routine calibration services, the Purchase Order should include authorization to proceed and return at current pricing, which can be obtained from a factory customer service representative.

Warranty – All equipment and repair services provided by PCB Piezotronics, Inc. are covered by a limited warranty against defective material and workmanship for a period of one year from date of original purchase. Contact

PCB for a complete statement of our warranty. Expendable items, such as batteries and mounting hardware, are not covered by warranty. Mechanical damage to equipment due to improper use is not covered by warranty. Electronic circuitry failure caused by the introduction of unregulated or improper excitation power or electrostatic discharge is not covered by warranty.

Contact Information – International customers should direct all inquiries to their local distributor or sales office. A complete list of distributors and offices can be found at www.pcb.com. Customers within the United States may contact their local sales representative or a factory customer service representative. A complete list of sales representatives can be found at www.pcb.com. Toll-free telephone numbers for a factory customer service representative, in the division responsible for this product, can be found on the title page at the front of this manual. Our ship to address and general contact numbers are:

PCB Piezotronics, Inc.
3425 Walden Ave.
Depew, NY14043 USA
Toll-free: (800) 828-8840
24-hour SensorLineSM: (716) 684-0001
Website: www.pcb.com
E-mail: info@pcb.com



PCB工业监视和测量设备 - 中国RoHS2公布表
 PCB Industrial Monitoring and Measuring Equipment - China RoHS 2 Disclosure Table

部件名称	有害物质					
	铅 (Pb)	汞 (Hg)	镉 (Cd)	六价铬 (Cr(VI))	多溴联苯 (PBB)	多溴二苯醚 (PBDE)
住房	○	○	○	○	○	○
PCB板	X	○	○	○	○	○
电气连接器	○	○	○	○	○	○
压电晶体	X	○	○	○	○	○
环氧	○	○	○	○	○	○
铁氟龙	○	○	○	○	○	○
电子	○	○	○	○	○	○
厚膜基板	○	○	X	○	○	○
电线	○	○	○	○	○	○
电缆	X	○	○	○	○	○
塑料	○	○	○	○	○	○
焊接	X	○	○	○	○	○
铜合金/黄铜	X	○	○	○	○	○
本表格依据 SJ/T 11364 的规定编制。						
○：表示该有害物质在该部件所有均质材料中的含量均在 GB/T 26572 规定的限量要求以下。						
X：表示该有害物质至少在该部件的某一均质材料中的含量超出 GB/T 26572 规定的限量要求。						
铅是欧洲RoHS指令2011/65/ EU附件三和附件四目前由于允许的豁免。						

CHINA RoHS COMPLIANCE

Component Name	Hazardous Substances					
	Lead (Pb)	Mercury (Hg)	Cadmium (Cd)	Chromium VI Compounds (Cr(VI))	Polybrominated Biphenyls (PBB)	Polybrominated Diphenyl Ethers (PBDE)
Housing	O	O	O	O	O	O
PCB Board	X	O	O	O	O	O
Electrical Connectors	O	O	O	O	O	O
Piezoelectric Crystals	X	O	O	O	O	O
Epoxy	O	O	O	O	O	O
Teflon	O	O	O	O	O	O
Electronics	O	O	O	O	O	O
Thick Film Substrate	O	O	X	O	O	O
Wires	O	O	O	O	O	O
Cables	X	O	O	O	O	O
Plastic	O	O	O	O	O	O
Solder	X	O	O	O	O	O
Copper Alloy/Brass	X	O	O	O	O	O

This table is prepared in accordance with the provisions of SJ/T 11364.

O: Indicates that said hazardous substance contained in all of the homogeneous materials for this part is below the limit requirement of GB/T 26572.

X: Indicates that said hazardous substance contained in at least one of the homogeneous materials for this part is above the limit requirement of GB/T 26572.

Lead is present due to allowed exemption in Annex III or Annex IV of the European RoHS Directive 2011/65/EU.

DOCUMENT NUMBER: 21354

DOCUMENT REVISION: C

ECN: 45605

**OPERATION MANUAL FOR
ICP[®] PRESSURE SENSORS
MODELS 101A, A02, A03, A04, A05, A06
MODELS 111A21, A22, A23, A24, A26**

1.0 INTRODUCTION

These two miniature sensor series are intended for general purpose pressure measurements. Eight models in the series, 101A02, 101A03, 101A04, 101A06, 111A22 and 111A23, 111A24 and 111A26 are acceleration compensated.

Models 101A, 101A05, and 111A21 also have acceleration compensation but are recommended for applications where acceleration compensation is not critical.

Other applications for these sensors include the monitoring of pulsating pneumatic and hydraulic pressures in R & D and industrial applications.

2.0 DESCRIPTION

This series consists of sensors with three basic mechanical configurations and six different sensitivities (.5, 1.0, 5.0, 10, 40 and 50 mV/psi). Each model is basically similar in internal design and construction.

The pressure element used in the 101A, 101A05 and 111A21 sensors is the Model 111A. The acceleration-compensated models in both the 101A and 111A20 Series use the Model 113A quartz element.

These elements consist of an IC source follower amplifier and an acceleration-compensated or non-compensated quartz package. The amplifier and element are joined as an inseparable unit.

Refer to "General Guide to ICP[®] Instrumentation," G-0001 for a complete treatment of the ICP[®] concept.

The Models 111A21, 111A22, 111A23, 111A24 and 111A26 are in the basic probe configuration as illustrated below and are installed with a hollow clamp nut with 5/16-24 external threads.

The housing of these models is at electrical ground potential.

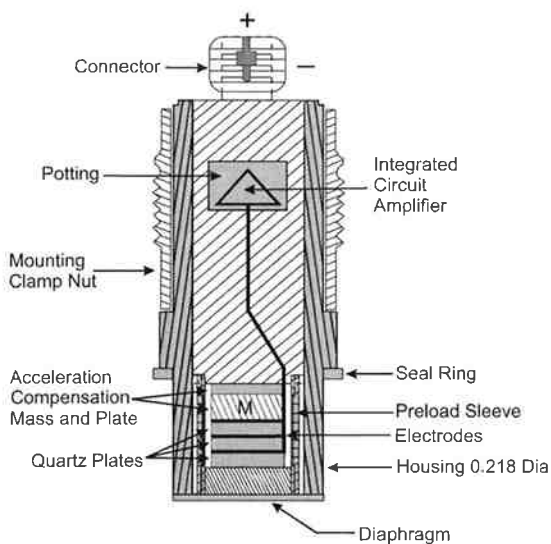

Typical ICP[®] Probe Style Sensor

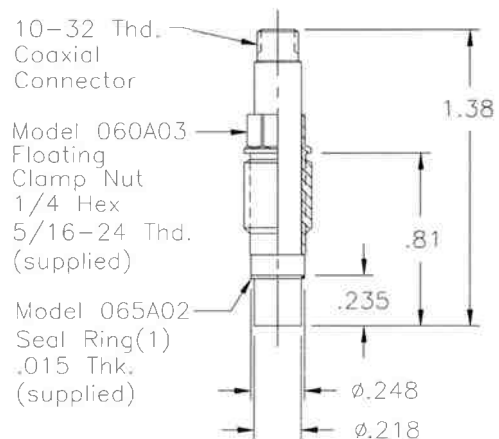

Series 111A20 Probe Style Sensor

The Models 101A02, 101A03, 101A04, 101A05 and 101A06 use the same basic pressure probe mounted in a 3/8-24 threaded mounting adaptor with shoulder seal. The probe is assembled into the adaptor at the factory in an "off-ground" configuration, i.e. the probe body is electrically insulated from the external mounting adaptor body. Do not attempt to disassemble probe and adaptor.

**OPERATION MANUAL FOR
ICP[®] PRESSURE SENSORS
MODELS 101A, A02, A03, A04, A05, A06
MODELS 111A21, A22, A23, A24, A26**

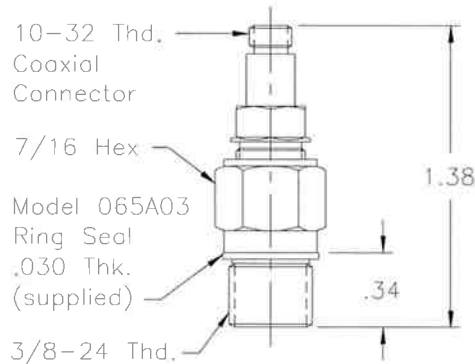

Models 101A02 through A06: Thread Mount Design, Ground-Isolated Sensor

The remaining Model 101A uses the same inner probe design but in a 3/8-24 threaded adaptor with floating clamp nut to permit adjustment of diaphragm depth where it is necessary to adapt to various wall thickness. This model, supplied only in the low-pressure (250 psi) version, is also "off-ground."

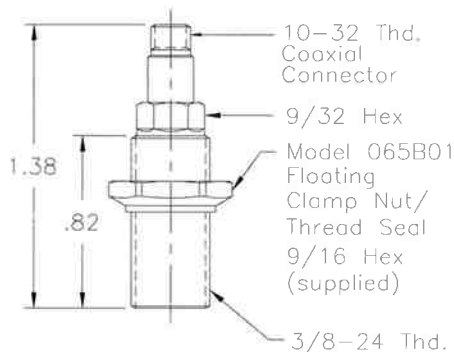

Model 101A: Thread Mount Design With Floating Clamp Nut, Ground-Isolated

3.0 INSTALLATION

Accompanying this manual is an installation drawing for your specific model. Prepare mounting ports in accordance with the installation drawing for the specific model, paying particular attention to sealing surfaces.

These surfaces must be smooth and free from chatter marks, nicks, and other irregularities which could preclude a pressure-tight seal.

Seals are provided with each sensor and should always be used. Extra seals for all standard models are in stock at the factory. Replace seals when they become unserviceable.

3.1 FLASH TEMPERATURE PROTECTION

In some cases, e.g. where flash temperatures such as those generated by combustion processes are present, it may be necessary to thermally insulate the diaphragm to minimize spurious signals generated by these effects.

Common black vinyl electrical tape has been found to be an effective insulating material in many cases. One or more layers may be used across the end of the diaphragm without affecting response or sensitivity.

A silicone rubber coating approximately .010 inches thick has also been proven effective in many applications. General Electric RTV type 106 silicone rubber is recommended.

Apply the rubber coating and allow to cure in accordance with the manufacturer's instructions. Use standard coaxial cable between the sensor and power unit.

4.0 OPERATION

It is necessary only to supply the sensor with a 2 to 20 mA constant current at +20 to +30 VDC through a current-regulating diode or equivalent circuit. See Guide G-0001B for powering and signal conditioning information pertaining to all ICP[®] instrumentation.

Most of the signal conditioners manufactured by PCB have an adjustable current feature allowing a choice of input currents from 2 to 20 mA. In general, for lowest noise (best resolution), choose the lower current ranges. When driving long cables (to several

**OPERATION MANUAL FOR
ICP[®] PRESSURE SENSORS
MODELS 101A, A02, A03, A04, A05, A06
MODELS 111A21, A22, A23, A24, A26**

thousand feet), use the higher current, up to 20 mA maximum. Consult the factory to determine if higher current settings are required.

Switch power on and observe reading of bias monitoring voltmeter on front panel of power unit.

If indicator is in green section of indicator panel, the IC amplifier is producing proper bias (+8 to 14 VDC), the cable connections are normal, and the system is ready to operate.

If the pointer moves into the red area of the fault monitor meter, output is zero and a short is indicated. Short could be located in amplifier, cable, connectors, or power unit.

If pointer moves into the yellow area of the fault monitor meter, an open circuit is indicated with full power supply voltage. An open circuit could be the result of a faulty amplifier, an open cable, or open connectors.

5.0 POLARITY

This sensor series produces a positive-going output voltage for increasing pressure input.

6.0 LOW-FREQUENCY RESPONSE

The low-frequency response of an ICP[®] system is determined by:

1. The discharge time constant of the sensor.
2. If AC-coupled at the power unit, the coupling time constant.

Depending upon the sensor's built-in discharge time constant, repetitive output signals slowly or rapidly move toward a stable condition where the average signal level corresponds to a zero voltage position.

In this position, the area contained by the signal above zero is equalized with the area below zero. Such output signal behavior is typical of an AC-coupled system. Since the signal output from the sensor is inherently AC coupled, any static pressure influence applied to the unit will decay away according to the nature of the system's discharge time constant.

Consult Section 7.0 in General Guide G-0001B for detailed explanation of low-frequency characteristics of ICP[®] instruments.

7.0 CALIBRATION

Piezoelectric sensors are dynamic devices, but static calibration techniques can be employed if discharge time constants are sufficiently long. Generally, static calibration methods are not employed when testing sensors with a discharge time constant that is less than several hundred seconds.

To calibrate statically, direct couple the sensor to the DVM readout using a T-connector from the "xducer" jack or use the Model 484B in the calibrate mode.

Apply pressure with a dead weight tester and take readings quickly. Release pressure after each calibration point.

For the shorter TC series, rapid step functions of pressure are generated by a pneumatic pressure pulse calibrator or dead weight tester and readout is by recorder or storage oscilloscope.

PCB offers a complete recalibration service. Consult factory for details.

8.0 MAINTENANCE

Although ICP[®] sensors have low output impedance and are not usually affected by moisture, in extreme environments it is good practice to protect cable connections with shrink tubing.

The miniature size and sealed construction of the 101A and 111A20 ICP[®] series precludes field maintenance.

	ENGLISH	SI	
Performance			
Measurement Range(for ±5V output)	1 kpsi	6895 kPa	
Useful Overrange(for ± 10V output)	2 kpsi	13,790 kPa	[1]
Sensitivity(± 0.5 mV/psi)	5.0 mV/psi	0.73 mV/kPa	
Maximum Pressure(static)	10 kpsi	68,950 kPa	
Resolution	20 mpsi	0.14 kPa	
Resonant Frequency	≥ 400 kHz	≥ 400 kHz	
Rise Time(Reflected)	≤ 1.5 μ sec	≤ 1.5 μ sec	
Low Frequency Response(-5 %)	0.005 Hz	0.005 Hz	
Non-Linearity	≤ 2.0 % FS	≤ 2.0 % FS	[2]
Environmental			
Acceleration Sensitivity	<0.002 psi/g	<0.0014 kPa/(m/s ²)	
Temperature Range(Operating)	-100 to +275 °F	-73 to +135 °C	
Temperature Coefficient of Sensitivity	≤ 0.2 %/°F	≤ 0.36 %/°C	
Maximum Flash Temperature	3000 °F	1649 °C	
Maximum Vibration	2000 g pk	19,614 m/s ² pk	
Maximum Shock	20,000 g pk	196,140 m/s ² pk	
Electrical			
Output Polarity(Positive Pressure)	Positive	Positive	
Discharge Time Constant(at room temp)	≥ 100 sec	≥ 100 sec	
Excitation Voltage	20 to 30 VDC	20 to 30 VDC	
Constant Current Excitation	2 to 20 mA	2 to 20 mA	
Output Impedance	≤ 100 Ohm	≤ 100 Ohm	
Output Bias Voltage	8 to 14 VDC	8 to 14 VDC	
Physical			
Sensing Geometry	Compression	Compression	
Sensing Element	Quartz	Quartz	
Housing Material	17-4 Stainless Steel	17-4 Stainless Steel	
Diaphragm	Invar	Invar	
Sealing	Epoxy	Epoxy	
Electrical Connector	10-32 Coaxial Jack	10-32 Coaxial Jack	
Weight	0.21 oz	6 gm	

OPTIONAL VERSIONS		
Optional versions have identical specifications and accessories as listed for the standard model except where noted below. More than one option may be used.		
E - Emralon coating		[4]
Coating	Emralon	Emralon
Electrical Isolation	10 ⁸ Ohm	10 ⁸ Ohm
Supplied Accessory : Model 065A08 Isolation ring 0.250"OD x 0.218" ID x 0.027" thk anodized aluminum (3)		
Supplied Accessory : Model 065A22 Isolation Seal, .250" OD x .218" ID x .015", Torlon or Vespel (3)		
H - Hermetic Seal		[4]
Sealing	Welded Hermetic	Welded Hermetic
J - Ground Isolated		[4][5]
N - Negative Output Polarity		[4]
S - Stainless Steel Diaphragm		[4]
Diaphragm	316L Stainless Steel	316L Stainless Steel
W - Water Resistant Cable		[4]

NOTES:

[1] For +10 volt output, minimum 24 VDC supply voltage required. Negative 10 volt output may be limited by output bias.

[2] Zero-based, least-squares, straight line method.

[3] See PCB Declaration of Conformance PS023 for details.

[4] For sensor mounted in thread adaptor, see adaptor installation drawing for supplied accessories.

[5] Used with optional mounting adaptor.

SUPPLIED ACCESSORIES:

Model 060A03 Clamp nut, 5/16-24-2A thd, 1/4" hex, stainless steel (1)

Model 060A05 Clamp nut M7 x 0.75-6g thd (1)

Model 065A02 Seal ring, sensor flush mount, 0.248" OD x 0.219" ID x 0.015" thk, brass (3)

Model 065A05 Seal sleeve sensor recess mount 0.248" OD x 0.221" ID x 0.240" thk 17-4 (1)

Entered: AP	Engineer: MJK	Sales: KWW	Approved: BAM	Spec Number:
Date: 3/19/2013	Date: 3/19/2013	Date: 3/19/2013	Date: 3/19/2013	111-1240-80

	Phone: 716-684-0001 Fax: 716-684-0987 E-Mail: info@pcb.com
3425 Walden Avenue, Depew, NY 14043	



All specifications are at room temperature unless otherwise specified.
 In the interest of constant product improvement, we reserve the right to change specifications without notice.
 ICP® is a registered trademark of PCB Group, Inc.

111-1210-90

PCB Piezotronics Inc. claims proprietary rights in the information disclosed hereon. Neither it nor any reproduction thereof will be disclosed to others without the written consent of PCB Piezotronics Inc.

REVISIONS			
REV	DESCRIPTION	ECN	APP'D
P	CORRECT SPELLING OF "PREPARATION"	27868	DM 5/07
R	REMOVE WELD LINE	27890	DM 1/08

ELECTRICAL CONNECTOR
10-32 UNF-2A

3

MODEL 060A03
CLAMP NUT
.25[6.3] HEX
MAT'L: 17-4 (H900)

5/16-24 UNF-2A

4 QUARTZ SENSOR WITH
BUILT IN AMPLIFIER

LENGTH	
CHARGE	1.32[33.5]
ICP	1.48[37.6]

.235 ± .001
[5.97 ± .03]

.81 [20.6]

.34 [8.5]

∅.248 ^{+.000}/_{-.001} [6.30 ^{+.00}/_{-.03}]

∅.218 ^{+.000}/_{-.001} [5.54 ^{+.00}/_{-.03}]

MOUNTING HOLE PREPARATION

1 FLUSH INSTALLATION

∅.221 ± .002 [5.61 ± .05]
THRU
5 ∟∅.250 ^{+.003}/_{-.000} [6.35 ^{+.08}/_{-.00}]
X .520 [13.20] ▽
∟∅.277 [7.04]
X .480 [12.19] ▽
5/16-24 UNF-2B
X .400 [10.16] ▽

2 RECESSED INSTALLATION

5 ∟∅.250 ^{+.003}/_{-.000} [6.35 ^{+.08}/_{-.00}]
X .750 [19.05] ▽
∟∅.277 [7.04]
X .480 [12.19] ▽
5/16-24 UNF-2B
X .400 [10.16] ▽

MODEL 065A02
SEAL
.015 [.38] THK

"A"

MODEL 065A05
SEAL
.240 [6.09] LONG

"B"

5 FOR BEST RESULTS USE A MINIMUM 63 [1.6] SURFACE FINISH.

4 IC AMP AND SENSOR ARE SEALED ASSEMBLIES AND SHOULD BE RETURNED TO THE FACTORY FOR SERVICE AND/OR REPAIR.

3 RECOMMENDED TORQUE ON .25 [6.3] HEX: 25-35 IN. LBS. [2.8-3.9 Nm]

2 DIMENSIONS "A" AND "B" TO SUIT USER REQUIREMENTS.

1 THESE DIMENSIONS FOR .750 [19.05] THICK WALL. COUNTERBORE FOR THICKER WALLS.

UNLESS OTHERWISE SPECIFIED TOLERANCES ARE:

DIMENSIONS IN INCHES	DIMENSIONS IN MILLIMETERS [IN BRACKETS]
DECIMALS XX ± .01 XXX ± .005	DECIMALS X ± 0.3 XX ± 0.13
ANGLES ± 2 DEGREES	ANGLES ± 2 DEGREES
FILLETS AND RADII .003 - .005	FILLETS AND RADII [0.07 - 0.13]

DRAWN	ECB	1/3/08	MFG	JP	1/3/08
CHK'D	DM	1/3/08	ENGR	ECB	1/3/08
APP'D	RF	1/3/08	SALES	RWM	1/3/08
TITLE					
INSTALLATION DRAWING MODELS 111A, 112A, 113A, 113B SERIES PRESSURE SENSOR					

PCB PIEZOTRONICS^{INC}
3425 WALDEN AVE. DEPEW, NY 14043
(716) 684-0001 E-MAIL: sales@pcb.com

CODE IDENT. NO. 52681	DWG. NO. 111-1210-90
SCALE: 2X	SHEET 1 OF 1

PCB Piezotronics Inc. claims proprietary rights in the information disclosed hereon. Neither it nor any reproduction thereof will be disclosed to others without the written consent of PCB Piezotronics Inc.

REVISIONS

REV	DESCRIPTION	ECN	APP'D
D	CORRECT SIMENSION	25685	DM 1/07
E	CORRECT SPEELING OF "PREPARATION"	27868	DM 14/07

8686

ELECTRICAL CONNECTOR
10-32 THREAD

2 MODEL 060A05
CLAMP NUT
1/4 HEX
M7 X 0.75-6g

1 PRESSURE SENSOR
W/ BUILT IN AMPLIFIER

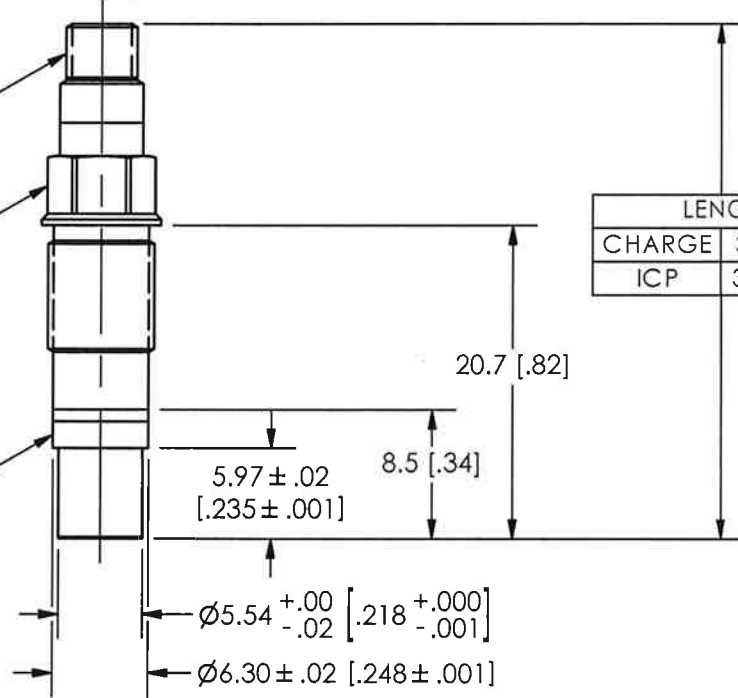

MOUNTING HOLE PREPARATION

4 FLUSH INSTALLATION
Ø5.61 ± .05 [Ø.221 ± .002]
THRU
└─┬─┐ Ø6.35 ^{+0.13} / _{-.00} [.250 ^{+0.005} / _{-.000}]
X 13.21 [.520] ▽
M7 X 0.75-6H
X 10.16 [.400] ▽
PERFECT THREAD

RECESSED INSTALLATION
└─┬─┐ Ø6.35 ^{+0.13} / _{-.00} [.250 ^{+0.005} / _{-.000}]
X 19.05 [.750] ▽
M7 X 0.75-6H
X 10.16 [.400] ▽
PERFECT THREAD

MODEL 065A02
SEAL
.38 [.015] THICK

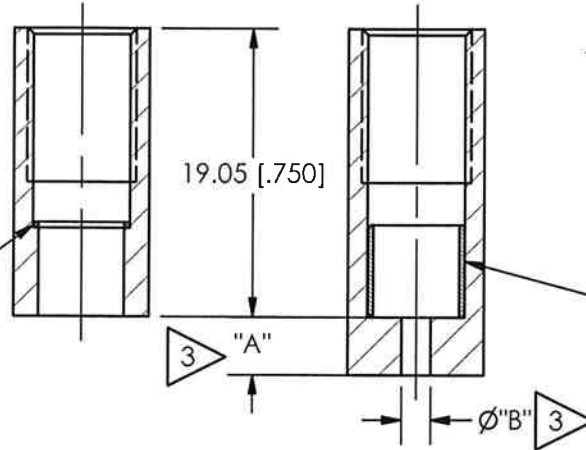

MODEL 065A05
SEAL
6.10 [.240] LONG

4 THESE DIMENSIONS FOR 19.0 [.75] THICK WALL. └─┬─┐ THICKER WALLS TO THIS DIMENSION.

3 DIMENSIONS "A" AND Ø"B" TO SUIT USER REQUIREMENTS.

2 RECOMMENDED TORQUE ON CLAMP NUT 225-395 Ncm [25-35 INCH POUNDS].

1 THIS IS A SEALED ASSEMBLY AND SHOULD BE RETURNED TO THE FACTORY SHOULD SERVICE BECOME NECESSARY.

UNLESS OTHERWISE SPECIFIED TOLERANCES ARE:

DIMENSIONS IN INCHES

DIMENSIONS IN MILLIMETERS
[IN BRACKETS]

DECIMALS XX ± .01
XXX ± .005
ANGLES ± 2 DEGREES

DECIMALS X ± 0.3
XX ± 0.13
ANGLES ± 2 DEGREES

FILLETS AND RADII
.003 - .005

FILLETS AND RADII
[0.07 - 0.13]

DRAWN	ECB	12/26/07	MFG	PRR	12/26/07
CHK'D	DM	2/26/07	ENGR	ECB	12/26/07
APP'D	RF	12/26/07	SALES	MFG	12/26/07

TITLE
INSTALLATION DRAWING
MODELS M111A, M112A, M113A, M113B SERIES
PRESSURE SENSOR

PCB PIEZOTRONICS INC.

3425 WALDEN AVE. DEPEW, NY 14043
(716) 684-0001 E-MAIL: sales@pcb.com

CODE IDENT. NO.
52681

DWG. NO.

8686

SCALE: 2X

SHEET 1 OF 1